



IBT200A

20 MHz – 20.0 GHz BIAS-T

REV B
March 2016

Key Features



- Wide Band, 20 MHz ~ 20.0 GHz
- Low Insertion Loss, 0.50 dB Typ.
- 1.22 :1 VSWR
- 220 mA DC Current Handling
- 2 W CW Power Handling
- Precision Machined Housing
- Single DC Power Supply
- Meet MIL-STD-202g

Applications

- Up to 20.0 GHz Band
- Satellite Communications
- Broadcast
- RF Bench Tests
- Mobile Base Station Applications

Absolute Maximum Ratings

Parameters	Units	Ratings
DC Voltage	V	16
DC Current	mA	220
Input Power, CW	dBm	33
Storage Temperature	°C	-40 ~ +85
Operating Temperature	°C	-40 ~ +85

Note: Heat sink is required for high power applications!

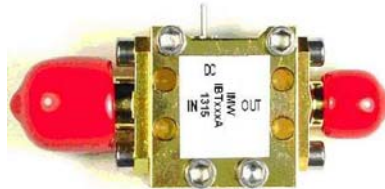

Specifications

Summary of the key electrical specifications at 25°C

Index	Testing Item	Symbol	Test Constraints	Min	Typ	Max	Unit
1	Frequency Range	BW	50 Ohm Impedance	0.02		20.0	GHz
2	Insertion Loss	S_{21}	0.02 – 20.0 GHz		0.5	1.0	dB
3	VSWR	SWR_i	0.02 – 20.0 GHz		1.22:1	1.5:1	Ratio
4	Isolation, RF to DC Port		0.02 – 20.0 GHz		40		dB
5	Maximum Power Handling	P_{MAX}	0.02 – 20.0 GHz, CW			33	dBm
6	Maximum DC Voltage	V_{DCMAX}				16	V
7	Maximum DC Current	I_{DCMAX}				220	mA
8	Operating Temperature	T_o		-40		+85	°C

Functional Block Diagram

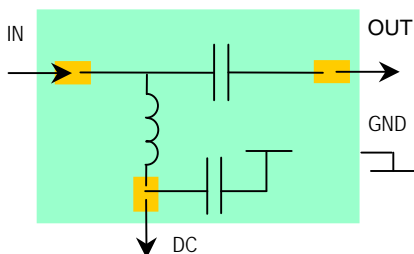

Outline, IP-4A Housing

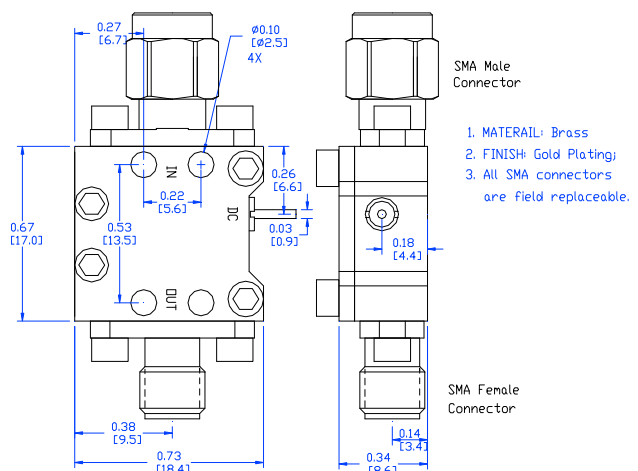

Ordering Information

Model Number	Connectors	
	IN	OUT
IBT200A	SMA Female	SMA Female

Specifications and information are subject to change without notice.



Typical Data

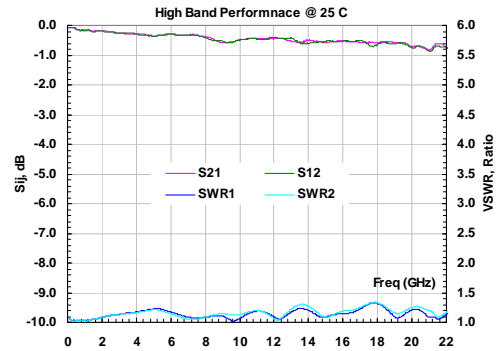
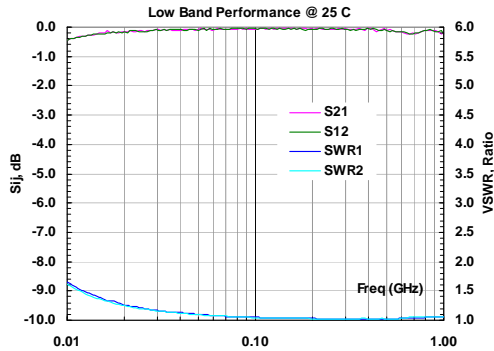

Application Notes:

A. SMA Torque Wrench Selection

Always use a torque wrench with 5 ~ 6 inch-lb coupling torque setting for mating the SMA cables to the amplifier. Never use torque more than 8 inch-lb wrench for tightening the mating cable to the connector. Otherwise, the permanent damage will occur to the SMA connectors of the amplifier. 8710-1582 (5 inch-lb) is one of the ideal torque wrench choice from Agilent Technology.

B. Mounting the Amplifier

Use three pieces of #2-56 with longer than 9/16" screws for mounting the amplifier on a metal-based chase. Flat and spring washers are needed to prevent the screw loosening during the shock and vibration. Always use the appropriate torque setting of the power screwdriver to mount them.
